

Electro Industries' MAKE-UP AIR

Ideal for energy efficient homes, Electro's Packaged Make-Up Air will provide tempered fresh air to help prevent negative pressure and the danger of backdrafting combustion appliances when high CFM kitchen exhaust hoods are used. This completely automatic system is the easiest way to meet compliance with the International Residential Code (IRC) which requires make-up air when 400 CFM or greater exhaust fans are used. The system is also compliant with the Protection Against Depressurization section in Canada's national building code.

STANDARD FEATURES

- Models available in 150, 350, 600, 900, 1050, and 1200 CFM
- Voltage - 120, 208, 240 VAC, single and three-phase
- WarmFlo® Digital Proportional Element Modulation
- Inlet and outlet digital temperature sensors for precise set points
- Integrated powered inlet damper
- Washable aluminum mesh filter
- Current transformer technology for full interlock with exhaust systems
- Multiple control inputs (i.e. end switches, zone valves, etc.)
- Easy programming for multi-speed kitchen exhaust fans
- LCD display provides status and temperatures
- Best in the industry warranty:
 - 20-year finned rod element warranty
 - 2-year parts warranty
- Made in the USA



NEW NO HEAT MODELS

- *NO HEAT models now available - same features and excellent quality as our standard Make-Up Air models*
- *No electric heating elements*
- *Easy to zone off an existing gas or electric boiler for heat!*

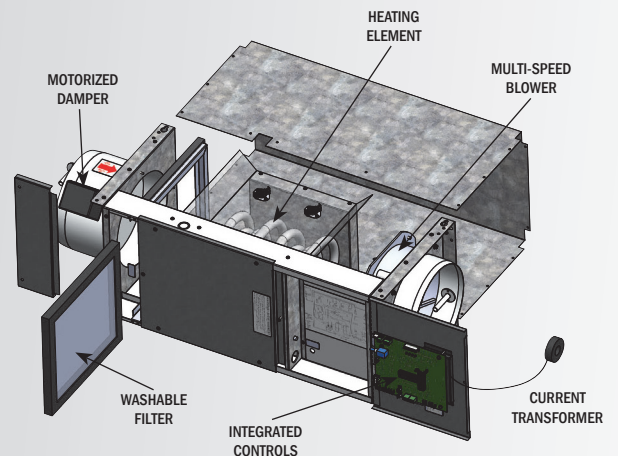

MAKE-UP AIR CODE REQUIREMENTS

Electro's Make-Up Air units check all the boxes for the 2015 International Mechanical Code, making it simply the best solution on the market.

Chapter 5 - Exhaust Systems Code	Electro's Solution	Code Compliance
<i>Such makeup air systems shall be equipped with a means of closure . . .</i>	Our Packaged Make-Up Air incorporates damper control .	✓
<i>. . . and shall be automatically controlled to start and operate automatically with the exhaust system.</i>	Our units incorporate current transformer logic to start and operate automatically the make-up air system.	✓
<i>Exhaust hood systems capable of exhausting in excess of 400 cfm (0.19 m³/s) shall be provided with makeup air at a rate approximately equal to the exhaust air rate.</i>	Packaged Make-Up Air is programmable or adjustable to closely match the exhaust rate .	✓

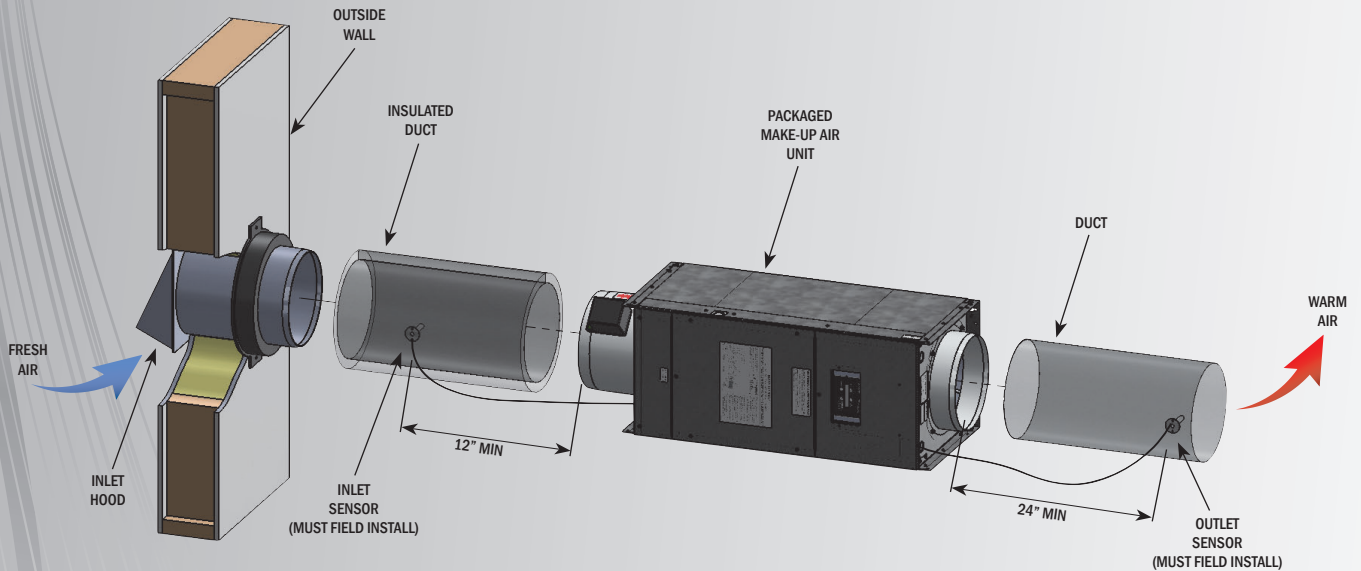

AVAILABLE SIZES

150 CFM	350 CFM	600 CFM	900 CFM	1050 CFM	1200 CFM
120V 1 Phase 0 - 1.6 KW	240/208V 1 Phase 208V 3 Phase 0 - 5 KW	240/208V 1 Phase 208V 3 Phase 0 - 10 KW	240/208V 1 Phase 208V 3 Phase 0 - 15 KW	240/208V 1 Phase 208V 3 Phase 0 - 15 KW	240/208V 1 Phase 208V 3 Phase 0 - 21.6 KW

TO LOCATE A CONTRACTOR OR DISTRIBUTOR IN YOUR AREA VISIT WWW.ELECTROMN.COM AND CLICK ON DEALER FINDER

All specifications subject to ELECTRO INDUSTRIES STANDARD TERMS AND CONDITIONS, download at www.electromn.com/terms.pdf.



ELECTRO INDUSTRIES

Monticello, Minnesota
800.922.4138
www.electromn.com