

WarmFlo® Select EM-WU*****-SL* Series

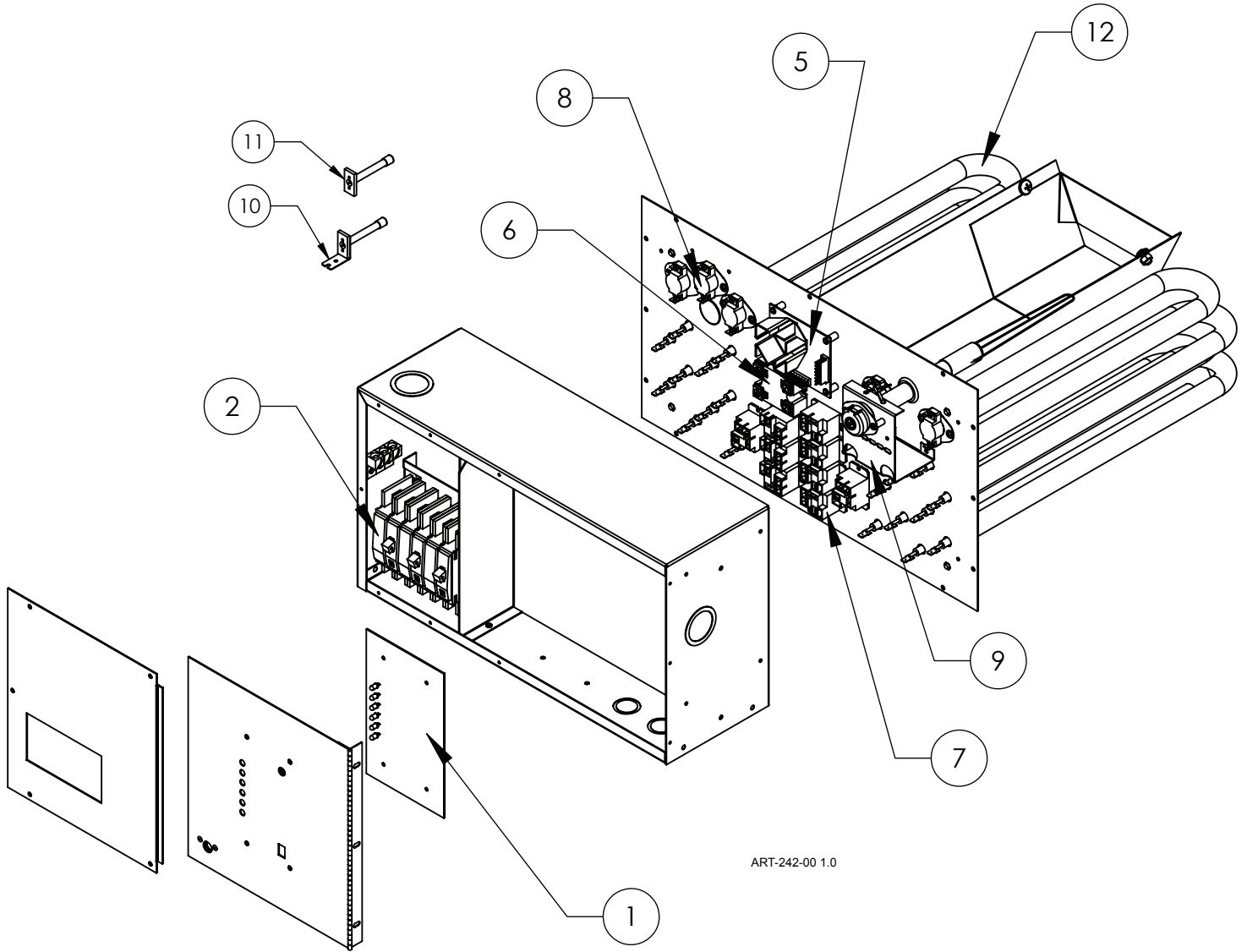

(SEE NEXT PAGE FOR PARTS LIST)

WarmFlo® Select

EM-WU*****-SL* Series

Replacement Part #		Description
EM-WU102S5-SL1 / EM-WU102S8-SL1		
1	WF5665SL1	WarmFlo + Control Board
2	5652	Square D 60-Amp Circuit Breaker
EM-WU153S5-SL1 / EM-WU153S8-SL1		
1	WF5665SL1	WarmFlo + Control Board
2	5650	Square D 30-Amp Circuit Breaker
2	5652	Square D 60-Amp Circuit Breaker
EM-WU204S5-SL1 / EM-WU204S8-SL1		
1	WF5665SL1	WarmFlo + Control Board
2	5652	Square D 60-Amp Circuit Breaker
EM-WU254S8-SL1		
1	WF5665SL1	WarmFlo + Control Board
2	5650	Square D 30-Amp Circuit Breaker
2	5652	Square D 60-Amp Circuit Breaker
EM-WU102D5-SL2 / EM-WU102D8-SL2		
1	WF5666SL2	WarmFlo SL2 Control Board
2	5652	Square D 60-Amp Circuit Breaker
EM-WU153D5-SL2 / EM-WU153D8-SL2		
1	WF5666SL2	WarmFlo SL2 Control Board
2	5650	Square D 30-Amp Circuit Breaker
2	5652	Square D 60-Amp Circuit Breaker
EM-WU204D5-SL2 / EM-WU204D8-SL2		
1	WF5666SL2	WarmFlo SL2 Control Board
2	5652	Square D 60-Amp Circuit Breaker
EM-WU254D8-SL2		
1	WF5666SL2	WarmFlo SL2 Control Board
2	5650	Square D 30-Amp Circuit Breaker
2	5652	Square D 60-Amp Circuit Breaker

Replacement Part #		Description
EM-WU102D5-SLC / EM-WU102D8-SLC		
1	WF5641SLT	WarmFlo SLC Control Board
1a	UIC9266 R-	Microchip v. 17.0*
2	5652	Square D 60-Amp Circuit Breaker
EM-WU153D5-SLC / EM-WU153D8-SLC		
1	WF5641SLT	WarmFlo SLC Control Board
1a	UIC9266 R-	Microchip v. 17.0*
2	5650	Square D 30-Amp Circuit Breaker
2	5652	Square D 60-Amp Circuit Breaker
EM-WU204D5-SLC / EM-WU204D8-SLC		
1	WF5641SLT	WarmFlo SLC Control Board
1a	UIC9266 R-	Microchip v. 17.0*
2	5652	Square D 60-Amp Circuit Breaker
EM-WU254D8-SLC		
1	WF5641SLT	WarmFlo SLC Control Board
1a	UIC9266 R-	Microchip v. 17.0*
2	5650	Square D 30-Amp Circuit Breaker
2	5652	Square D 60-Amp Circuit Breaker
EM-WU102D5-SLT / EM-WU102D8-SLT		
1	WF5641SLT	WarmFlo SLT Control Board
1a	UIC9266 R-130	Microchip v. 17.3*
2	5652	Square D 60-Amp Circuit Breaker
EM-WU153D5-SLT / EM-WU153D8-SLT		
1	WF5641SLT	WarmFlo SLT Control Board
1a	UIC9266 R-130	Microchip v. 17.3*
2	5650	Square D 30-Amp Circuit Breaker
2	5652	Square D 60-Amp Circuit Breaker
EM-WU204D5-SLT / EM-WU204D8-SLT		
1	WF5641SLT	WarmFlo SLT Control Board
1a	UIC9266 R-130	Microchip v. 17.3*
2	5652	Square D 60-Amp Circuit Breaker
Common Parts for the EM-WU*****-SLT Series		
13	EM5642	SLT I/F (Not Shown)
Common Parts for the EM-WU*****-SL* Series		
5	WFPDC5632	Relay Driver Board
6	4038KIT	50-Amp Triac Kit
7	5128C	30-Amp DC Relay
8	5633	118° Auto High Limit
9	EM5729	High Limit Probe
10	WFS25F	Outdoor Sensor
11	WFS5F	Duct Sensor
12	EM5620	2.5 kW SpinFin Element