

ELECTRO EZ-MATE™

Installation & Operating Instructions

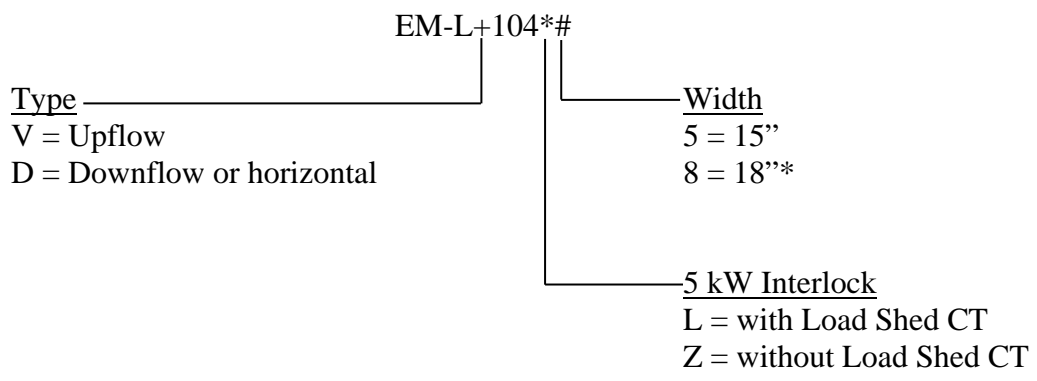

This model series must use software chip version 10.00 or higher.

Application

- Dual heat – gas or oil furnace conversion
- 34,000 Btu capacity
- WarmFlo technology – outdoor and plenum sensing
- Potentially can work with existing 100-amp service
- Furnace must be in good working condition

Conventional H/C Roomstat Only – either Heat Pump or Air Conditioning

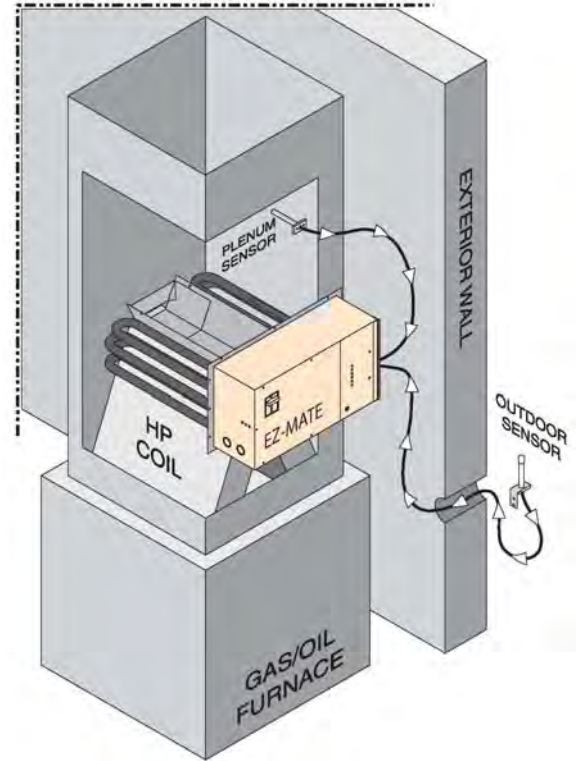

DO NOT DESTROY THIS MANUAL. PLEASE READ CAREFULLY AND KEEP IN A SAFE PLACE FOR FUTURE REFERENCE BY A SERVICE TECHNICIAN.

Drawings: EH808, EH810, EH811, ES815, XX017



Table of Contents

Introduction	1
Building Service Entrance Comments	1
Specification Chart	2
Product Dimensions	2
Installation Requirements	3
Mechanical Installation	
Upflow	4
Downflow or Horizontal	6
Electrical Hookup	7
Mini Demand Controller – 5 kW Load Shed	9
Additional Hookup or Special System Equipment Concerns	9
Field Setup or Programming	12
Operation Indicators	14
Stat Override Timer (SOT)	15
Handheld Analyzer/Laptop Software	15
Troubleshooting	16
Installation Checkout	18
Drawings Included:	EH808
	EH810
	EH811
	ES815
	XX017

Introduction

The intended application for this product is summarized on the cover page. If this does not fit your application needs or HVAC system design, Electro Industries manufactures other products which may fit your requirement. Do not modify or attempt to use this model other than its designed and intended usage.

- Electro-Mate/WarmFlo plenum heater, up to 25 kW – EM-WU or EM-WD Series with appropriate I/F module
- Basic plenum heater, without WarmFlo – EM-LV or EM-LD Series
- Plenum heater, HeatChoice – EH-***.*
- Basic duct heater – EM-WE or EM-DI Series
- Electric furnace – HE-H-**-**
- Complete Dual Energy Furnace – HD-D or HD-W Series

When installed according to this installation manual and inspected by your local power company representative, your dual heating system will qualify for special off-peak electric or dual fuel kWh rates.

This repackaged model series includes the basic, patented, Electro-Mate mechanical design – type of element, element position, directed airflow, enclosure cooling plate, approved zero clearance A-coil or furnace, etc. In addition, this EZ-Mate has a special controller which allows for simplified control wiring, easy heat pump interface, and special arrangements for minimizing service entrance upgrade.

- Smart controller, fully automatic
 - Outdoor and warm air temperature sensing
 - Knows building heat requirement
 - One room thermostat, entire system
 - Controls and reacts with heat pump and gas furnace
 - Applicable to single and ECM variable speed furnace blowers
 - Installer setup switch, selects heat pump or non-HP
- Mini Demand Controller
 - Monitors other appliances
- 34,000 Btu/h goes a long way

Dual Heat – since this is an addition to a gas or oil forced air furnace and ducting system, the furnace **system** must be totally installed and in good working condition prior to energizing or using this Electro-Mate. This also means all components of the HVAC system are in place and functional – furnace itself, heat pump (or AC), gas supply, permanent wired room thermostat, WarmFlo sensors, completed ducting system with proper filter, etc. There are certain interacting functions within the EZ-Mate controller, if the total system does not respond correctly it may lock up and there could be a loss of heating.

Warning: This unit shall not be operated (either heating section or blower) until the interior of the structure is completed and cleaned. This also means all duct work must be complete with filter, etc. The manufacturers' warranties are void if this unit is operated during structure construction.

Building Service Entrance Comments

This 10 kW unit can be considered firm load if there is adequate service entrance; however, this package includes design features which probably allow this EZ-Mate to be simply added to existing 100-amp service. By using a small donut CT as a component for a current detecting switch, a major appliance (not over 25-amp) can be detected to interlock or switch out ½ of this unit. This is an option which only applies if needed for the installation and if the CT is connected.

- 5 kW firm + 5 kW shed
 - NEC Appendix D, example 2a – normal major appliance – water heater, dryer, **and** 7 kW electric heat

Specification Chart

Model Number	EM-L+104*#
kW rating	10
Btu/h	34000
Voltage/Phase	240/1
Circuit Breaker	60
Amps per CB	42
Source Feed	1
Elements	4
Relays	4
Min. CFM	700
Max. Temp. Rise	45° F
Shipping Weight	24 lbs.

Product Dimensions

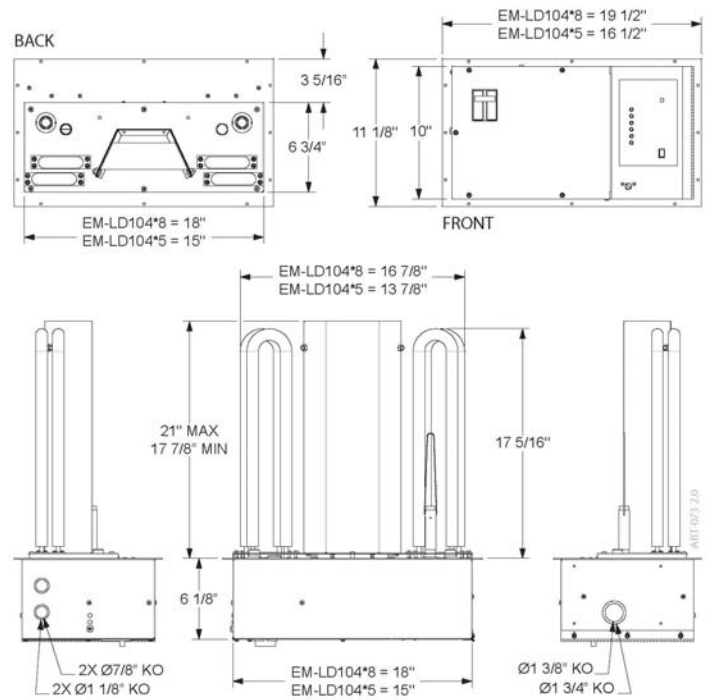
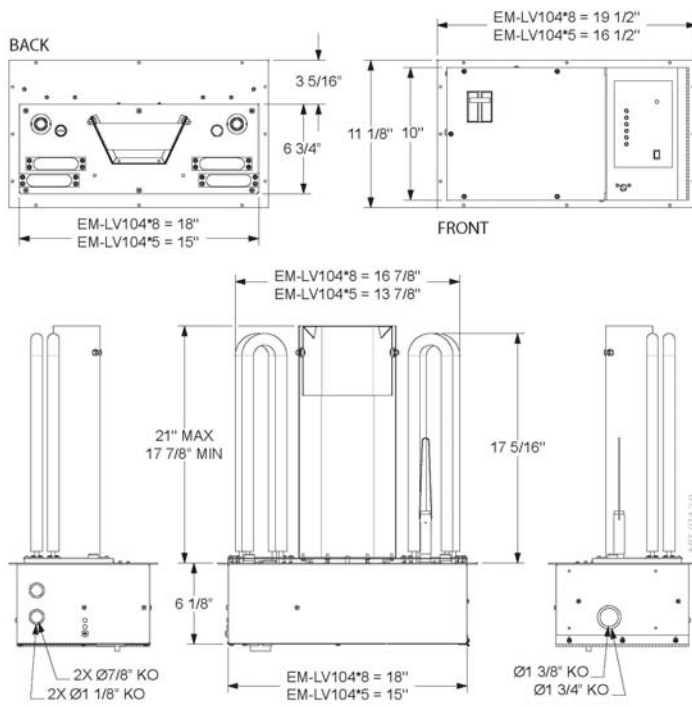

Installation Requirements

1. All installation work must be performed by trained, qualified contractors or technicians. Electro Industries, Inc., sponsors installation and service schools to assist the installer. **Visit our web site at electromn.com for upcoming service schools.**

WARNING

ALL ELECTRICAL WIRING MUST BE IN ACCORDANCE WITH NATIONAL ELECTRIC CODE AND LOCAL ELECTRIC CODES, ORDINANCES, AND REGULATIONS.

WARNING

OBSERVE ELECTRIC POLARITY AND WIRING COLORS. FAILURE TO OBSERVE COULD CAUSE ELECTRIC SHOCK AND/OR DAMAGE TO THE EQUIPMENT.

CAUTION

This unit can only be used for its intended design as described in this manual. Any internal wiring changes, modifications to the circuit board, modifications or bypass of any controls, or installation practices not according to the details of this manual will void the product warranty, the CSA/us certification label, and manufacturer product liability. Electro Industries, Inc., cannot be held responsible for field modifications, incorrect installations, and conditions which may bypass or compromise the built-in safety features and controls.

2. This installation manual and Electro-Mate products relate only to the addition of the Electro-Mate plenum heater to the furnace ducting system external to the gas or oil force air furnace. The owner/installer assumes all responsibility and/or liability associated with any needed installation of the gas/oil furnace, fuel system, flue, chimney, etc. Any instructions or comments made within this manual (or factory phone assistance) relating to the gas/oil furnace are provided as comments of assistance and “helps” only.

CAUTION

This unit shall not be operated (either heating section or blower) until the interior of the structure is completed and cleaned. This also means all duct work must be complete with filter, etc. Both manufacturers’ warranties are void if this unit is operated during structure construction.

CAUTION

Hazards or unsafe practices could result in property damage, product damage, severe personal injury and/or death.

Remember, safety is the installer’s responsibility and the installer must know this product well enough to instruct the end user on its safe use.

Safety is a matter of common sense - - a matter of thinking before acting. Professional installers have training and experienced practices for handling electrical, sheet metal, and material handling processes. Use them.

Mechanical Installation Upflow

Using this sketch and visualizing the Electro-EZ-Mate installation, work through the following eight steps:

Step 1

Observe and select insert location, furnace plenum

- a. Above A-coil
- b. Unit hole cutout at A-coil end
 - 2 sides of plenum choice, not 4
- c. Hole cut plenum side, 8" free space above A-coil top
- d. 10" minimum, between control box and plenum top
- e. All distribution ducts above A-coil top

Step 2

Measure plenum width **and** depth

- a. Step 1 determines facing side (hole cut decision)
- b. Width
 - 17" or less – 15" model
 - 20" or less – 18" model
 - 21" or greater – 18" model with baffling (see below)
- c. Depth
 - 21" or less – no baffling
 - 21" or greater – need rear baffling (see below)

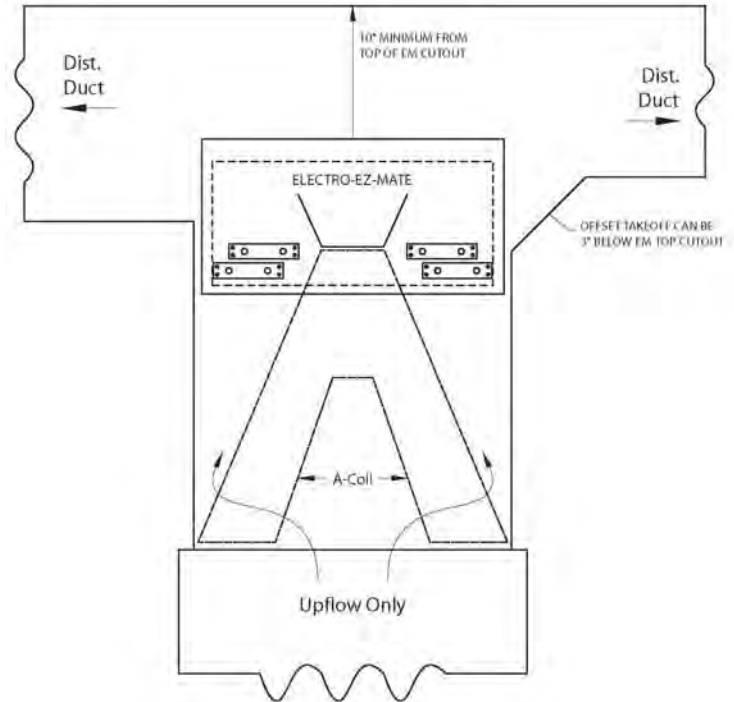

If your application falls in the 21" or greater mentioned above, field fabricate inside plenum baffling as shown.

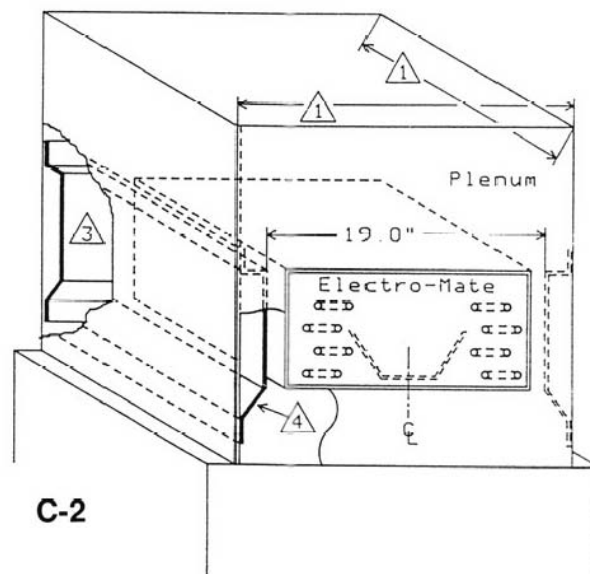

Step 3

Cut insert hole

- a. Template provided in documentation package – use 8” opening for this model series

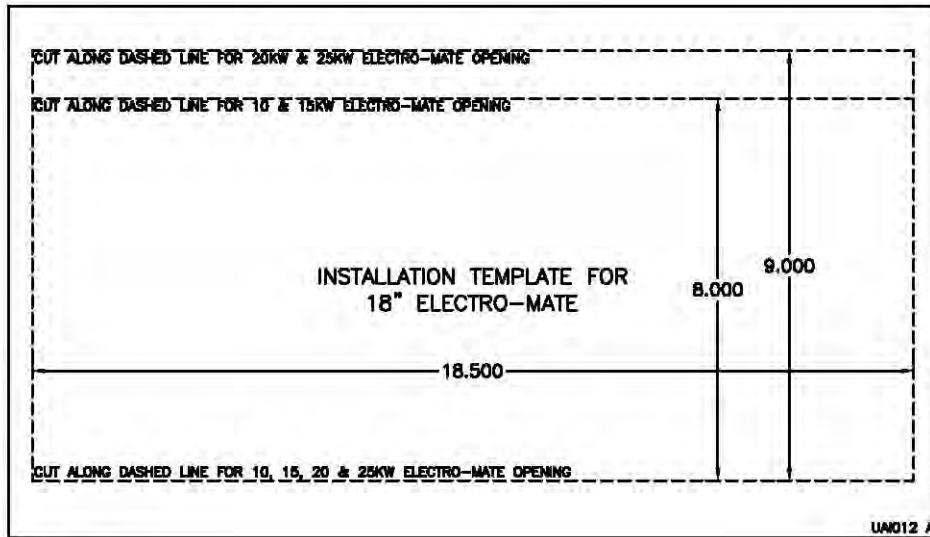

FRONT SIDE

Step 4

Add necessary baffling

- a. See Step 2 for determination and if required

Step 5

Insert unit and bolt in place

- a. Extend center V deflector to plenum depth
- b. Do not drill into refrigerant lines
- c. Note airflow decal
- d. Seal as required

Step 6

Install WarmFlo sensors

- a. Outdoor (OT) – extend to easiest location
 - Attempt to shade from direct sun
- b. Supply warm air (ST) – 12” to 16” above control box

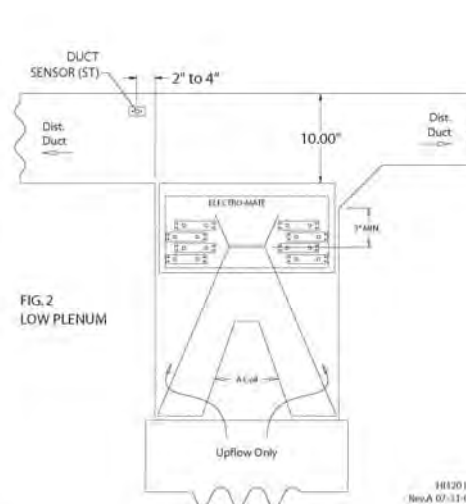
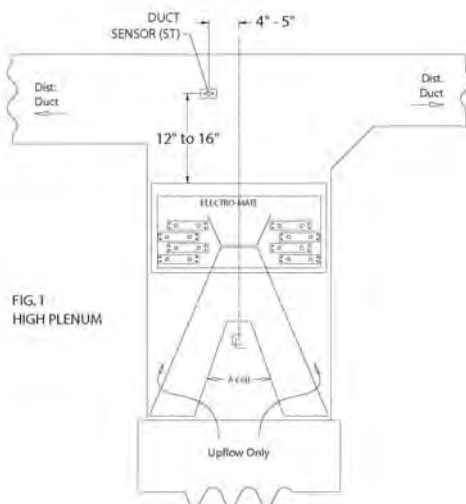

Step 7

Be prepared to assist electrician with control wiring

- a. This also includes determination whether CT's should interlock a major appliance
 - Dryer
 - Next choice could be oven unit
- b. Electrical hookup section details this load shed CT
- c. If utility load control is not used or required, verify jumper between BLU and BLU/WH remains

Step 8

System checkout

- a. Responsibility of the contractor who "sold the job"
- b. Warranty sheet suggests minimal steps
- c. Complete warranty sheet and send to Electro Industries

The Electro-Mate is designed with a special double plate at the element mounting. Cool air from the blower must blow between these two plates. Therefore, the Electro-Mate must be inserted into the base plenum such that the mounting plate is even with the edge of the hot air outlet hole. Do not necessarily line up the Electro-Mate control box with the furnace cabinet front. The concern is the hole in the bottom of the furnace mating with Electro-Mate elements.

Mechanical Installation Downflow or Horizontal

Must use the model with "D" in the fourth digit. The basic instructions represented above apply, but the location of inserting this EZ-Mate in relationship to the refrigerant coil will depend upon whether it is air conditioning or heat pump.

Air conditioning – if using a standard A-coil located under the furnace (driving the air backwards through the A-coil), install this EZ-Mate between the bottom of the furnace and the top of the A-coil. Follow the above 8 steps as they apply.

Heat pump – in order for the heat pump to function properly, this electric heating unit must be on the warm side of the HP refrigerant coil. The exact location (related to the coil output) and spacing will determine the type of coil and the overall ducting situation. If you need to locate this EZ-Mate under a standard A-coil drip pan, you must allow **at least 12"** space between the top of this unit's control box and the bottom of the drip pan. With this arrangement the 15" unit is the best choice, **but** you must build in the sides with a baffling arrangement shown in previous Step 2. Since the A-coil drip pan bottom opening is relatively small, there is no problem bringing the plenum down to a 15" width regardless of the size of the A-coil. Again proceed through the 8 steps as they apply.

Note: The duct sensor (ST) is installed on the warm side or airflow after this unit. Use spacing dimensions as shown in Step 6 above.

The Electro-Mate is designed with a special double plate at the element mounting. Cool air from the blower must blow between these two plates. Therefore, the Electro-Mate must be inserted into the base plenum such that the mounting plate is even with the edge of the hot air outlet hole. Do not necessarily line up the Electro-Mate control box with the furnace cabinet front. The concern is the hole in the bottom of the furnace mating with Electro-Mate elements.

Installation, wiring – except for a shipped loose included second hi-limit probe, all electrical, hookup, operation, etc. is basically the same as the upflow model. This additional hi-limit probe is code required for downflow. Install directly beneath the unit (sensing maximum temperature when the blower is running). Inside the main enclosure are two red wires coming from the installed hi-limit probe going to the control board HL tabs. Remove one of these wires, wire nut to the red wire on this second probe and return the other red wire from this second probe to the tab. In other words, both hi-limit probes will be connected in series. They both represent a closed contact.

Electrical Hookup

WARNING

DISCONNECT ALL ELECTRICAL POWER BEFORE ELECTRICALLY CONNECTING OR SERVICING THE UNIT. FAILURE TO DISCONNECT THE ELECTRICAL POWER BEFORE WORKING ON THIS PRODUCT CAN CREATE A HAZARD LEADING TO PERSONAL INJURY OR DEATH.

Line Voltage

The nameplate and/or Installation and Operating Manual specification page provides kW rating and operating current requirements. Select the proper wire size to comply with your type of wire routing and NEC field wiring requirements.

Field connection is at this product's furnished circuit breaker. This integrated circuit breaker is a proper local disconnect.

WARNING

USE ONLY COPPER WIRE FOR CONNECTION TO THE CIRCUIT BREAKER TERMINALS AND INSIDE THIS PRODUCT'S CABINET.

WARNING

TO AVOID THE RISK OF ELECTRIC SHOCK OR DEATH, WIRING TO THE UNIT MUST BE PROPERLY GROUNDED. FAILURE TO PROPERLY GROUND THE UNIT CAN RESULT IN A HAZARD LEADING TO PERSONAL INJURY OR DEATH.

Remote Sensor

Reference hookup drawing EH808, pages 1 and 2 as appropriate.

Duct Sensor (ST) – location was shown in the mechanical section, Step 6.

If there is not adequate plenum distance, pick the largest distribution duct and install towards the top of the horizontal duct. Locate, common sense, in the maximum warm air stream.

The key is getting this sensor in the maximum warm air stream, the air coming through the A-coil fins will all be on the edge of the plenum.

Note: The black tip inside of the white tube is the sensor itself. It must be positioned slightly sticking out of the white tube. The only purpose of the white tube is physical protection, once it is installed it is okay to push out the sensor ¼" to ½" to make it more sensitive and faster responding to the warm air stream.

Outdoor sensor – extend sensor to an outdoor location properly sampling the outdoor winter temperature. The north side may pick up too much shading and winds, but the south side should be avoided unless there is a position which will shade the sun.

Use care in selecting location so the sensor does not pick up false temperature from the heat pump outdoor unit, from refrigerant line sets, dryer vent, reflection off of steel siding, etc. Also do not install the sensor in a plastic box because it will falsely trap and pick up radiant sun temperature.

Other Sensor Related Comments

The factory supplied OT cable is 25 feet. If additional cable length is required, you must use the following rules for extending the cable.

- Use unshielded (low capacitance, preferred twisted) 3 or 4-wire low voltage cable.
- 50 feet is maximum.
- Do not, under any circumstances, use leftover wires within the thermostat cable going out to the outdoor unit.
- Route the sensor cable making sure you do not crimp, cut, staple, or damage the cable in any way.
- Keep sensor cables at least 12” away from any line voltage wiring, romex, etc.
- Cut to length. Do not bundle additional wire.

For easy sensor cable disconnect and reconnect, the WarmFlo board has a plug-in 4-place terminal block. Before disconnecting, you will notice two red wires are under one screw and two white wires is under the COM screw. The black wire represents the data information from each sensor and must be connected to the appropriate OT or ST screw.

The sensor has polarity, is sensitive to wrong voltage, must be protected from static voltage, etc. Do not cross connect or inadvertently short out sensor wires with power on. Permanent destruct damage may result.

Room Thermostat

Use conventional (not heat pump with O and compressor Y) heat/cool, 1H/1C. A conventional 2H/2C can be used for 2-stage AC and/or 2-stage gas, see page 9. It can be mechanical, digital, power-robbing, battery operated, setback, etc. If required, set heat anticipator to 0.2.

Note: Do not, even with heat pump, use a heat pump thermostat.

Connect the standard R, W, G, Y stat terminals to the control board upper left terminal block. If the specific roomstat requires common or C, this can be picked up from a tab on the board bottom left.

Outdoor Unit, Air Conditioning

Connect the outdoor unit two wires to the control board right **two** terminal block points marked AC.

Outdoor HP Unit (Single Speed)

This system is setup for the primary four wires – R, Y, RV, C. Connect to the control board upper right four terminal block points marked HP.

Defrost – if the installer user desires faster plenum heat during defrost, the outdoor unit W1 (W2 or anything else) can be connected to the “E” tab. **Caution:** This is not necessarily universal with all heat pumps, this should and must be tested by the installer if so connected.

Gas Furnace (or Oil with Fan Center Terminal Wiring Strip)

The 24-volt power for this unit comes from the furnace 40VA transformer.

For single blower speed or basic furnace use the standard four wiring points – R, W, C, G. Connect to control board, bottom left.

If this is a variable speed blower, GE ECM motor, add the 5th wire for a Y to Y connection. With this 5th wire speed connection you will want to go to the highest speed furnace terminal. This will relate if you have a Y1 and a Y2. Suggest using Y2 unless installer elects to add relay as detailed on the next page.

Other Furnace Situations or Special Wiring Requirements

See next page for a variety of items which may or may not relate to your specific installation.

Mini Demand Controller – 5 kW Load Shed

If, based upon service entrance sizing, there is a requirement to interlock with a major appliance; proceed to install the current sensing CT.

Depending upon local codes, this CT may or may not be allowed within the service panel.

Select a major appliance load at approximately 5 kW (larger will have no benefit) which has limited usage. At the major appliance unit J-box or the service panel breaker for this major appliance, remove one 240 leg wire, strip through the CT, and replace to the same breaker screw terminal point.

- If using more than one appliance load, it must be the same 240 leg (phasing) for each appliance.

Extend the two CT wires to the EZ-Mate inside control board bottom – CT and C tabs. Except for coming out of the service panel, this can be considered low voltage and low voltage wire and routing can apply. Reference drawing EH810.

WARNING

Current Transformers (CT) with unterminated wires can overheat and burn up their internal winding.

Do not plug in or install the CT to the WF+ board if there is current through the CT monitor wire.

SAFETY WARNING

CT UNTERMINATED WIRES CAN PRODUCE VERY HIGH VOLTAGE AND COULD BE A SAFETY SHOCK HAZARD.

Additional Hookup or Special System Equipment Concerns

Special Oil Furnace Comment

This controller is designed to interface directly with a furnace fan center containing 24-volt transformer (40VA or larger), blower relay, and a “W” function to operate the furnace. If this installation is for an **oil furnace** with only oil control “T and T” terminals, a special fan center will need to be added with an isolation relay at the “W” terminal so only isolated contacts are connected to the oil burner master control “T and T”. Another choice is to use a standard fan center and order EE-5053 relay with accompanying HD001 instruction sheet.

Wood Furnace or Other Non-Automatic Standby Furnace

WarmFlo works well with a wood furnace because it modulates (or adds to) the electric element to maintain a fixed temperature output. Thus the wood fire can “die down” and the supply sensor (ST) will make up electric element heat to keep the building comfortable. The other operating extreme is a “hot” wood fire where it is adequate to heat the building. In this case the supply sensor will be measuring temperature greater than required and turn off all elements automatically. However, there must be adequate controls on the wood furnace so that the discharge temperature does not exceed 180°F.

2-Stage Air Conditioning

In this case use a conventional 2H/2C room thermostat. The roomstat first stage W and Y are connected as detailed in the hookup. Roomstat Y2 is routed as follows, also reference drawing EH712.

Roomstat	Control Board Tab	Heat Pump	Furnace
Y2	COM		
	EL	Y2	Y2
	SB		

Note: Roomstat W2 could be used for 2 stage furnace as mentioned next.

2-Stage Gas Furnace

From Electro's experience all 2-stage gas furnaces must have a W1 before the furnace reacts to a W2 or special variable burner second control wire. Realizing this, the W2 functions from a 2H/2C roomstat can go directly to the furnace terminal block. There are some furnace manufacturers with a special variable burner and a special wire from the thermostat (typically V), simply route around this unit directly to the furnace. This EZ-Mate properly handles W1 which is the main control function for the furnace.

2-Stage or 2-Speed HP Compressor

This unit has plug-in arrangements for adding the Electro 2-speed heat pump interface module WF-HP2 if a less than ideal combination exists. The WF-HP2 allows conventional H/C 4-wire stat, conventional 2H/2C stat, or manufacturer's heat pump thermostat. There are setup jumpers and wiring arrangements specified in the installation manual for selecting the correct room thermostat. **All control wiring** and hookup is at the added WF-HP2 unit.

Note: With the WF-HP2 and all field wiring at that unit, this EZ-Mate controller has slightly different operational functions and user observations. The installer must carefully study the special paragraph within the WF-HP2 manual relating to EZ-Mate and Electro-Mate WF+ controller board. A summary of these items include:

- Keep the WF+ blue/blue white wire shorted, Load Control connects to HP2.
- HP2 special blower speed switch must be set in position "C".
- By definition, this will apply to HP, mode switch must be in either "Dual" or "No Gas" with the OT sensor installed.
- By definition and normal thermostat operation, the Y2 input must never be high without a Y1 input.
- Front panel lights – PWR, Hi-Limit, EL On – operate normally. Front panel lights – T-stat Call, HP Call, Standby must be ignored and will not correctly function.

Variable Speed, ECM Motor, Blower

Standard within this controller, the furnace Y connection will always have voltage relating to heating and cooling speed requirement. This Y function voltage is not present during standby. With this provided feature the ECM motor basically has two speeds – continuous air (G only) or G and Y combination for full heating and cooling speed. If the furnace being installed has additional intermediate blower speeds (Y1, Y2, BK, O, etc.) see next paragraph for the possibility of adding relays and using WarmFlo SPD B. If you're not implementing the intermediate speeds associated with a separate high speed in the next paragraph, the EZ-Mate control board Y is probably connected to the furnace highest speed or Y2.

Variable Speed Blower, Operate a Low Speed During Low Heat Requirements

Fall 2003 new WF II features allow selecting an outdoor temperature to change furnace blower speed. This EZ-Mate board has a programmable temperature which can trigger one or two additional relays for activating these additional furnace blower speed functions. Drawing EH811 provides the hookup details for this feature. The factory temperature defaults are:

ST	OT
SPD B – 104°	SPD B – 30°

Zone Damper Systems

Because of WarmFlo temperature sensing, this unit works very well with zone dampers. However, the dampers need to be in the horizontal ducts and at least 24" away from these electric elements. Since this unit uses 4-wire, heat/cool, thermostat connections; the zone damper must be a basic 4-wire thermostat device with an HVAC equipment terminal block simply labeled R, W, G, Y. This terminal block is connected to the EZ-Mate upper left same nomenclature terminal block.

Note: Strongly suggest wiring damper motors as normally open (NO).

Remotely Located Standby Override Switch

On the bottom of the board is an "SBSW" tab. Using an external switch between this "SBSW" tab and a common tab provides the same function as the front override switch. Whichever switch is in the up or

override position takes priority. In other words, they **both** need to be in the down position during **cooling**.

Note: All override switches (front panel and any options) must be in normal or electric position during cooling.

Note: This contact **also** follows front panel standby switch and all other standby functions such as SOT-S, etc.

Field Setup or Programming

It is extremely important the installer properly goes through this section and sets up the various switches to match the installation.

Warning: Power-down reset required whenever changing any of the switch positions on the back side of the board.

HP Reversing Valve Logic

Since this control board creates the reversing valve control wire for the heat pump, it is important the installer select the required logic for the heat pump installed. The control board top has a peg jumper and three pins. When the jumper is in the “C” position the heat pump O wire is high during cooling. If there is a requirement for high during heating, move jumper to the H position.

Select Configuration or Hardware Mode

For this EZ-Mate unit only two of the four positions are legal and should be used – **Dual** for heat pump or **ST & OT** for AC.

Non-Heat Pump (or AC) – ST & OT

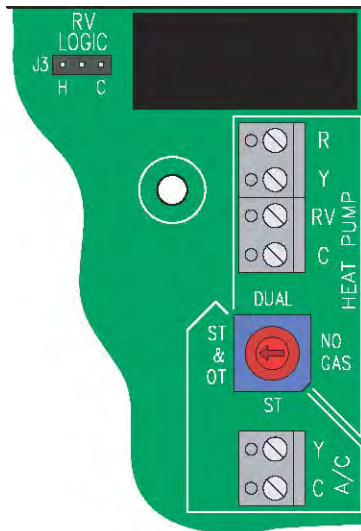

Heat Pump – Dual

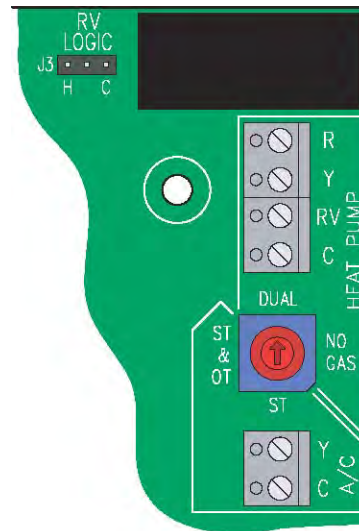

Important

Located on the WF+ board is a firmware chip that, along with the position of the application selection dial, determines a specific set of defaults. However, this can be programmed (altered) with optional plug-in WarmFlo Analyzer (WF-ANZ7).

⚠ WARNING

ADJUSTING THE APPLICATION SELECTION DIAL WILL ERASE ALL SPECIAL PROGRAMMING CHANGES.

Switchover Temperature (SW OVER)

Select the temperature where the unit should terminate **both** heat pump and electric section and use the furnace below the selected temperatures. The table relating to heat loss house size and location may help.

Ø = Disabled, no ODT switch-over

1 = -15°F

5 = 10°F

Factory set on #3.

2 = -10°F

6 = 20°F

3 = 0°F

7 = 30°F

4 = 5°F

Heat Loss	Minneapolis		Bismarck		Denver		DesMoines		Akron	
	HP	Non-HP	HP	Non-HP	HP	Non-HP	HP	Non-HP	HP	Non-HP
65,000	+5	③	+10	③	+10	③	+5	③	+10	③
55,000	0	+15	0	+10	+5	+20	0	+15	+5	+20
45,000	-10	+5	-10	0	0	+10	-10	+5	0	+10
35,000	-15	-10	-15	-15	-15	0	-15	-10	-15	0

Comment: For minimal gas use, suggest one setting colder than above.

Minimum Warm Air

This dial switch sets a “floor” or minimum operating temperature level. The supply temperature will never go below this point independent of outdoor temperature, heat pump output, etc.

0 = 90

4 = 98

Factory set on #3.

1 = 92

5 = 100

2 = 94

6 = 102

3 = 96

7 = 104

Comment: Suggest 94 or 96 for heat pump but probably 102 for non-heat pump.

Temperature (Efficiency Dial)

Located on the front cover is a red screwdriver adjustment dial with selection A through G. These A through G selections represent a supply temperature point at 0° outdoor. The closer the user or installer selection is to A, the flatter the heat loss curve or the higher the operating efficiency. The closer a selected setting is to G, the steeper the heat loss curve or the lower overall heat pump system efficiency. If the knob is turned to “full”, the controller DT is set at its maximum or 125°. It will bring in stages or electric elements as required to run at the “flat” or 125° point. This does **not** necessarily mean all stages are on or this is not the same as the “E” input tab. If there is not adequate airflow for the capacity of the unit and the 125° is reached before all stages or all modulation is on, it will simply operate at that point (see E input staging override paragraph under Troubleshooting section).

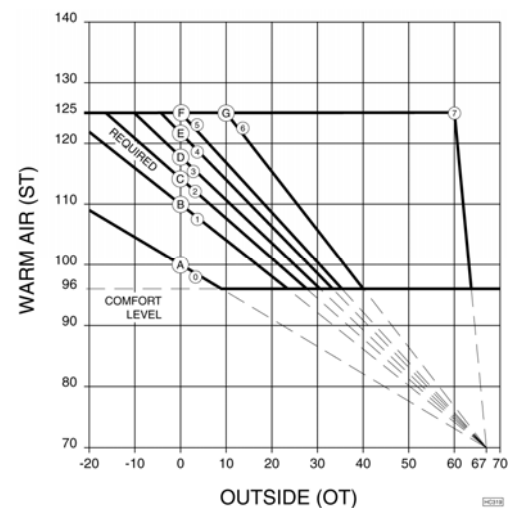

Heat loss curve – within the “brain” of the WarmFlo controller is a relationship of supply temperature (ST) to outdoor temperature (OT) measurement. As it gets colder outside, the higher the supply temperature in order to properly overcome the heat loss within the structure. This is the diagonal line between 67° outdoor and maximum Btuh (heat loss) at the coldest outdoor temperature. The slope of this line or the exact warm air position at the coldest temperature is established by the “efficiency” adjustment knob or dial.

Operation Indicators

Front Panel LED's

- **Hi-limit** – when the hi-limit probe (automatic reset or manual reset) opens this top red LED is on. The electric elements will be interrupted via a safety relay circuit whenever this HL LED is illuminated.
- **PWR ON** – indicates good fuse and 24-volt power source from the furnace terminal block.
- **EL mode** – this illuminates during electric heat function. In some ways this can be a utility load control indicator, but there are additional programmable functions which cause this unit to go to standby (see list in the Troubleshooting section).
- **HP/AC call** – the output “Y” screw terminal is active at 24 volts high. The outdoor unit should be on and running. This LED will be off when the OT sensor is below the setup ODT value.
- **T-stat call** – the room thermostat Y or E is active or 24 volts high.
- **Gas call** – the furnace “W” or terminal block feeding fan center W is 24 volts high.

Override Switch – the front panel slide switch (very similar to standard Electro-Mate DFC) is a direct hardware disabling of any WarmFlo and electric elements functions. The room thermostat heat call wire or function is directly controlling the fossil fuel or gas furnace. This function can also be on a remote switch, see previous statement for “SBSW” tab.

WARNING

THIS FRONT PANEL MANUAL OVERRIDE SWITCH IS A HARDWARE DIRECT TO GAS FURNACE FUNCTION. THUS THERE ARE NO BLOWER PURGE CYCLES. IF THE ELECTRIC ELEMENTS ARE ON AND HOT WHEN SWITCHING TO OVERRIDE AND IMMEDIATELY ALLOWING THE GAS FURNACE, OVERHEAT ON THE ELECTRIC ELEMENTS AND POTENTIAL ELECTRO-MATE MANUAL RESET IS POSSIBLE. THIS FRONT PANEL OVERRIDE SWITCH SHOULD ONLY BE ACTIVATED WHEN THERE IS NOT A ROOMSTAT HEAT CALL.

Note: This switch must be in the normal position during cooling.

Strip Heat Disable – To maximize heat pump system energy efficiency and preventing “accidental” unnecessary resistant strip heat when it is not required, this WarmFlo II disables or locks out strip heat elements based upon outdoor temperature.

Non-Heat Pump	Heat Pump
Stage 1 - 90° F	Stage 1 - 50° F
Stage 2 - 90° F	Stage 2 - 50° F
Stage 3 - 36° F	Stage 3 - 36° F
Stage 4 - 34° F	Stage 4 - 34° F

Sensor Monitor Indicators – in addition to using WarmFlo Analyzer or WarmFlo PC software to readout the temperature sensors, there is a built-in go/no-go type monitor visible on the green PWR ON second from the top LED.

- If there is detection of miswired or totally inoperative sensor, this LED has a blinking or pulse mode. By checking the pulsing pattern, the appropriate sensor can be identified.
- OT sensor – 1 blink every second
- ST sensor – 2 blinks every second
- Both bad – 3 blinks every second

WarmFlo Select, WarmFlo+, EZ-Mate, WF II

Selection Dial	Code	Stg. Enable	MU Time	ODT Mode	OT Function	SOT-S
Dual	HPDH ²	50°, 38°, 36°, 34°	90	HP	DT Cal.	90
ANZ-set	HPDF ²	50°, 38°, 36°, 34°	30	EL to SB	DT Cal.	90
No Gas	HPEL	50°, 38°, 36°, 34°	00	HP	DT Cal.	00
ST & OT	EMW	90°, 50°, 36°, 34°	60	EL to SB ¹	DT Cal.	90
ST	EMA	-	00	EL to SB ¹	Disable	90
-	HPFU	50°, 38°, 36°, 34°	30	HP	DT Cal.	90

¹ODT dial switch must be set on 0 = disable.

²EZ-Mate – dual is HPDF, not HPDH.

Other defaults, all Forced Air models.

SB RESET – enabled	ST SPD A – N/A
SOT-E – 000 (disabled)	ST SPD B – 105°
OT SPD A – N/A	CT STG DISABLE – all 0, except EZ-Mate = 3
OT SPD B – 20°	CT STG DISABLE – all 0, except EZ-Mate = 4

Stat Override Timer (SOT)

This is a field option internal timer which can be field programmed with WF analyzer to select a roomstat cycle run time. If this downloaded run time (typically 30 minutes) is exceeded before the thermostat is satisfied, the system automatically switches to either full electric elements or standby.

- SOT S – this is the longer set timer which allows transfer to standby if something might have happened to the electric system unmonitored.
- SOT E – this must be shorter time than above, is typically used to overcome morning setback pickup issues. In other words, if you would field download 20 minutes and you program the setback stat to begin bringing up the temperature 20 minutes prior to the wakeup time; and the system is not at the new higher temperature at the 20-minute point it will automatically add stages (DT flat) in order to more rapidly raise the building temperature. However, this also means you will be “short cycling” the HP compressor during other heat calls. The maximum run time for the compressor is then about 20 minutes at any time of the day or at any particular heat call.

Handheld Analyzer/Laptop Software

This test tool and/or software is available for temperature offset, field altering the program chip parameters and setup, and general assistance for troubleshooting.

The WF-ANZ*, version 4.12 update, now can be used to real time calculate CFM.

See the enclosed “WarmFlo Information” document (HD320) for functional details.

Troubleshooting

Comment: Also see the “WarmFlo Information” document (HD320) included with this manual.

Sensor Temperature Calibration – both remote sensors are digital electronic and factory calibrated. Normally these do not require field calibration or verification. However, if sensor temperature error is determined, use WarmFlo Analyzer test set or purchase special PC software disc and PC serial port cable. These plug-in devices allow direct readout of both temperatures, allows a visual determination of WarmFlo internal temperature settings, and can be used to offset either temperature sensor for troubleshooting and demonstration purposes. This is especially valuable during summer installation. Call factory and order test set device.

Override Staging, “E” Tab Input – during a normal roomstat heat call and E is jumpered to W, it brings on all four stages and essentially bypasses any temperature sensing or stage modulation functions. In other words, with an E input (still need the normal W stat input) this is simply a turn-on/turn-off device.

Heat pump application – with the E input the heat pump is still on and the user must have concern for adequate airflow when energizing all elements. E jumpered to W should never be considered a normal usage. This can be used during defrost, see previous hookup paragraph.

Load shed, CT input, verification – with the CT sensing a load greater than approximately 10 amps, observe stages 3 and 4 LED with energizing this monitored load. Stages 3 and 4 should go off (can also be monitored with clamp-on amp meter) and should return as soon as the monitored load is turned off. The AC voltage at the “CT” tab and common is approximately 2.4 when this interrupt is triggered.

Operational Conditions, Forcing Standby – these conditions are also monitored by the front panel EL mode light being off.

1. Utility Load Control
2. SOT S timeout
3. MU timeout
4. OT below switchover set point - configuration mode setup dial switch also defines switchover function
5. Front override switch
6. Option WF-HP2 or WF-LGR4 interface has setup a standby condition

Operational Conditions Which May Prevent Standby or Gas On

1. No call for heat - T-call LED is off
2. LED EL ON mode- utility is not controlling or front panel is not in override
3. Somehow stat terminal block Y is also energized or at 24 volts
4. Board K1 or K2 open/inoperative
5. Hang-up - power down, 10 seconds, power up

Operational Conditions Which May Prevent EL Stages On (No Stage LED's)

1. No call for heat - T-call LED is off
2. In standby mode, see previous section
3. Hang-up - power down, 10 seconds, power up

Conditions Which May Prevent Electric Elements On, With Staging LED's On

1. Mechanical hi-limit, front panel top LED on
2. Board K1 or K2 open/inoperative
3. Inoperative element relays
4. Inside AC to DC power supply board bad
5. Circuit breakers off
6. Burn 240 inside wires
7. Building power panel fusing or breakers

Outdoor Sensor (OT) Location – direct sunlight has a definite affect on sensor temperature reading. The sensor white tube must be “shadowed” from direct sun rays.

Troubleshooting/Repair Helps

1. This WarmFlo controller contains several interference suppression components, but as an electronic logic product, unpredictable and unusual transients or interferences may sometimes cause strange results. If the WarmFlo controller is “acting strange”, one immediate step would be power down reset. Simply turn off the 24-volt source power (probably furnace or air handler circuit breaker), when the green LED goes out, count to 10, and re-energize power supply.
2. The terminal blocks for control wire hook-up are designed for a wire insertion and screw clamp down. If there is no wire connected and the screw is loose, the screw may not necessarily make a good electrical contact to the inside components. Example – if you are jumpering the thermostat terminals without thermostat wire connection or if you are attempting to measure voltage on the screw head, you may get erroneous or unpredictable results if the screw is not tightened down.
3. Use general heating system logic information and basic understanding of the terminal block wiring functions when measuring voltage to determine proper operation of this module.
4. The outdoor sensor must be located outdoors for this controller to correctly operate. Do not leave the outdoor sensor “hang in conditioned space” and attempt to run this system.
5. Acquiring the WarmFlo Analyzer test set or the PC software and serial port hook-up cable (see previous page) is a positive tool for understanding and troubleshooting the WarmFlo controller. Either test set device can display all temperatures, real time evaluation of WarmFlo functions, provide temperature offsets for assimilating winter conditions, and reprogram the control chip (program stays with the actual controller board).

Bad sensor, safety – if the internal logic detects open sensor wire, incorrectly wired sensor, or some bad sensor transmitted value conditions; the green LED reverts to a pulsing mode. Basically the appropriate sensor is set internally to a 0° value and the WarmFlo main board only allows stage 1 and stage 2 on.

- OT sensor – 1 pulse every second
- ST sensor – 2 pulses every second
- Both bad – 3 pulses every second

Bad sensor, operating default condition – the detection of bad sensor forces the controller to a fixed stage operation.

- OT sensor
 - Stages 1 and 2 on, stages 3 and 4 off (5 kW maximum)
 - The WF-ANZ screen reads “254” or “BAD”
- ST sensor
 - Stages 1 and 2 on, stages 3 and 4 off (5 kW maximum)
 - The WF-ANZ screen reads “254” or “BAD”
- Both OT and ST sensors
 - Stages 1 and 2 on, stages 3 and 4 off (5 kW maximum)
 - The WF-ANZ screen reads “254” or “BAD”

Bad sensor, could disable cooling – depending upon the ODT setting a bad sensor, even during cooling, can affect the ODT of the compressor and the compressor will be off. Temporary fix is to set the ODT dial to “0” position and get the sensor fixed. Verify with plug-in Analyzer and/or no blinking green LED.

Analyzer readout, sensor temperature constant 32° or 0° – these two values represent digital bit patterns that are hard to predict an error function. A blinking green light may or may not be experienced. Typically the cable is too long, wrong type of sensor wire, or some electrical interference on the sensor cable.

Installation Checkout

Insert plenum thermometer 6" to 8" above the electric element section, position to measure the warm air from the electric elements. Proceed with the following procedure, observing the various staging action, element power current, and the outlet temperature.

- Turn on system in heat mode and verify proper heat pump and WarmFlo Select operation.
 - If it is above 50° F OT, the electric elements may be disabled within the internal logic. In the next steps the Analyzer can be used to force the OT to a low temperature.
 - With this specific controller and system combination it may require manually turning the heat pump compressor off for this test to prevent hi-limit overheating when both the heat pump and all stages on simultaneously. Typically the WarmFlo controller would never have all stages on when the heat pump is producing adequate warm air. The key point of this checkout is to verify adequate airflow for the specific kW size of the WarmFlo Select installed.
- Verify controller setup dial switch settings per previous section.
- Using WF Analyzer (or software) set the outside temperature (OT) to 5°F.
 - If WF Analyzer is not available, jumper R to E which will also bring on all stages. Warning – never leave E energized when not present to verify proper blower function when this bypass is used.
- Initiate thermostat call for heat:
 - Verify heat pump is operational and producing heat, not cooling.
- Verify red LED's are staging in, the system should go to all four stages.
- Verify electric element heating and plenum thermometer temperature is rising.
- With full heat output, wait 5 to 10 minutes to stabilize temperature and take the following readings:
 - Plenum temperature _____
 - 240 heating power, voltage _____
 - Measured 240 amps, current _____
 - Measured 24 transformer voltage _____
- As you perform this test monitor the Hi-Limit LED on the front of the door of the control box. This LED determines hi-limit cycling. If the red LED came on and you observed hi-limit cycling, corrective action will be required to make sure hi-limiting does not occur during normal operation.
 - Verify all airflow is through the electric elements (proper baffling, electric element positioning, etc.)
 - Increase airflow or determine ducting distribution problem loading the system.
 - Perhaps it can be assumed full electric element heat is not required when the compressor is running. If this is the decision, change the minimum warm air switch to #4. If this improves the air delivery situation, provide informational technique to make sure the user never sets the minimum warm air switch to #5, #6, or #7. If #4 still produced hi-limit, try #3. For proper heating comfort #3 would probably be the lowest acceptable number. Again if you cannot sustain non-hi-limiting operation with #3, a serious evaluation of the basic airflow, blower, ducting system will be required to match your specific kW electric unit sizing.

ELECTRO-EZ-MATE AIR CONDITIONER HOOKUP

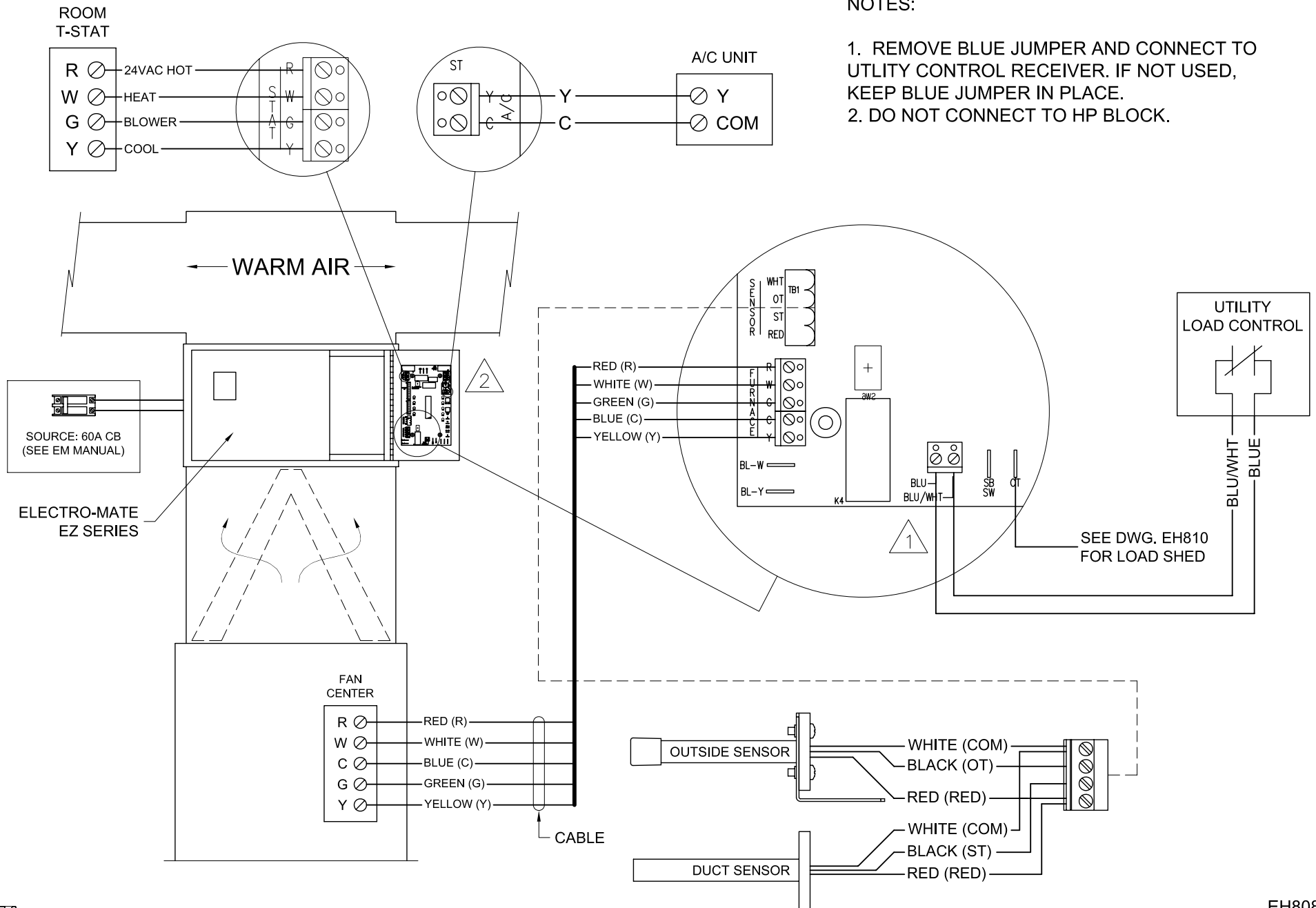

ELECTRO-EZ-MATE HEAT PUMP HOOKUP

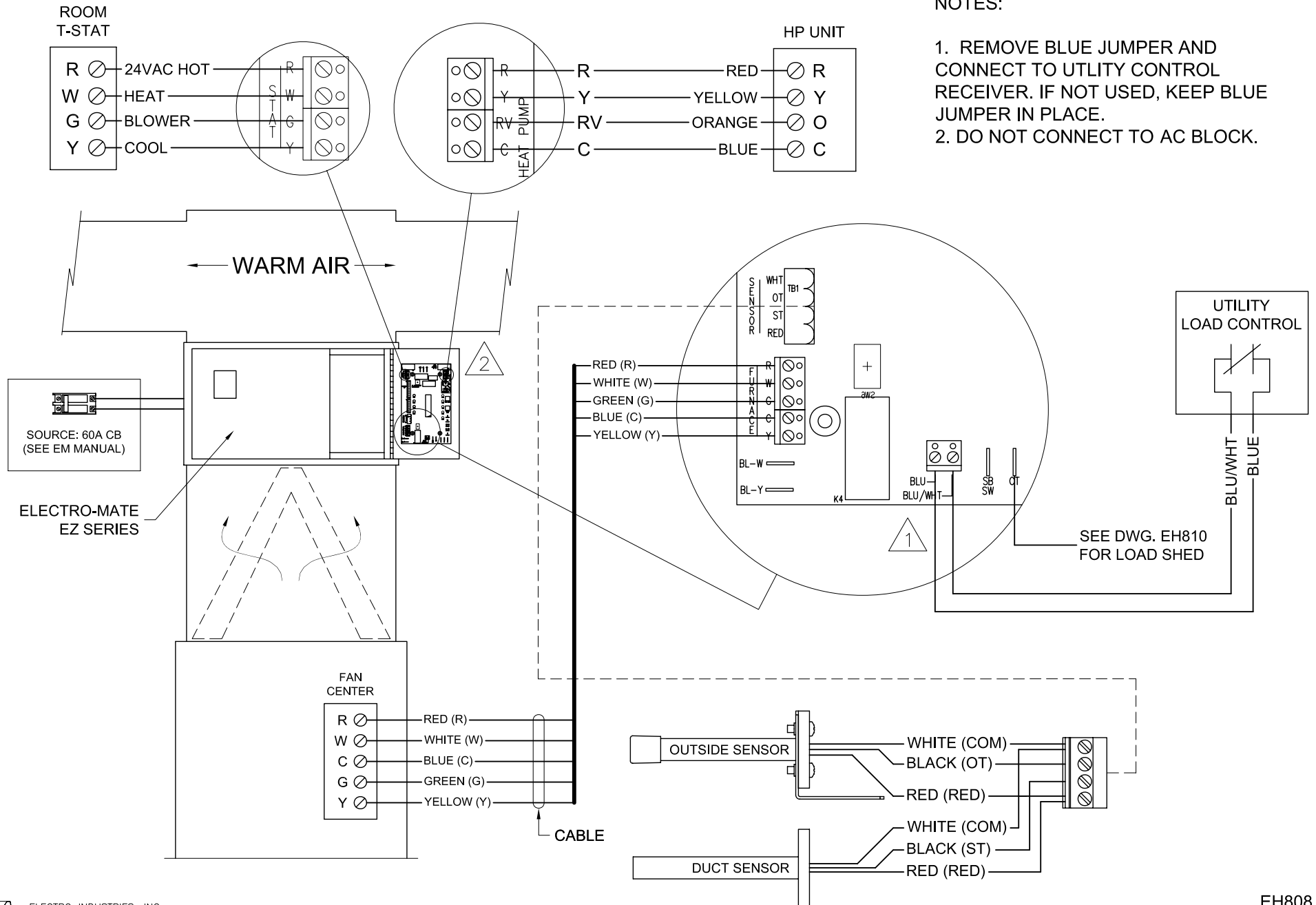

ELECTRO-EZ-MATE

ADD 5KW LOAD SHED HOOKUP

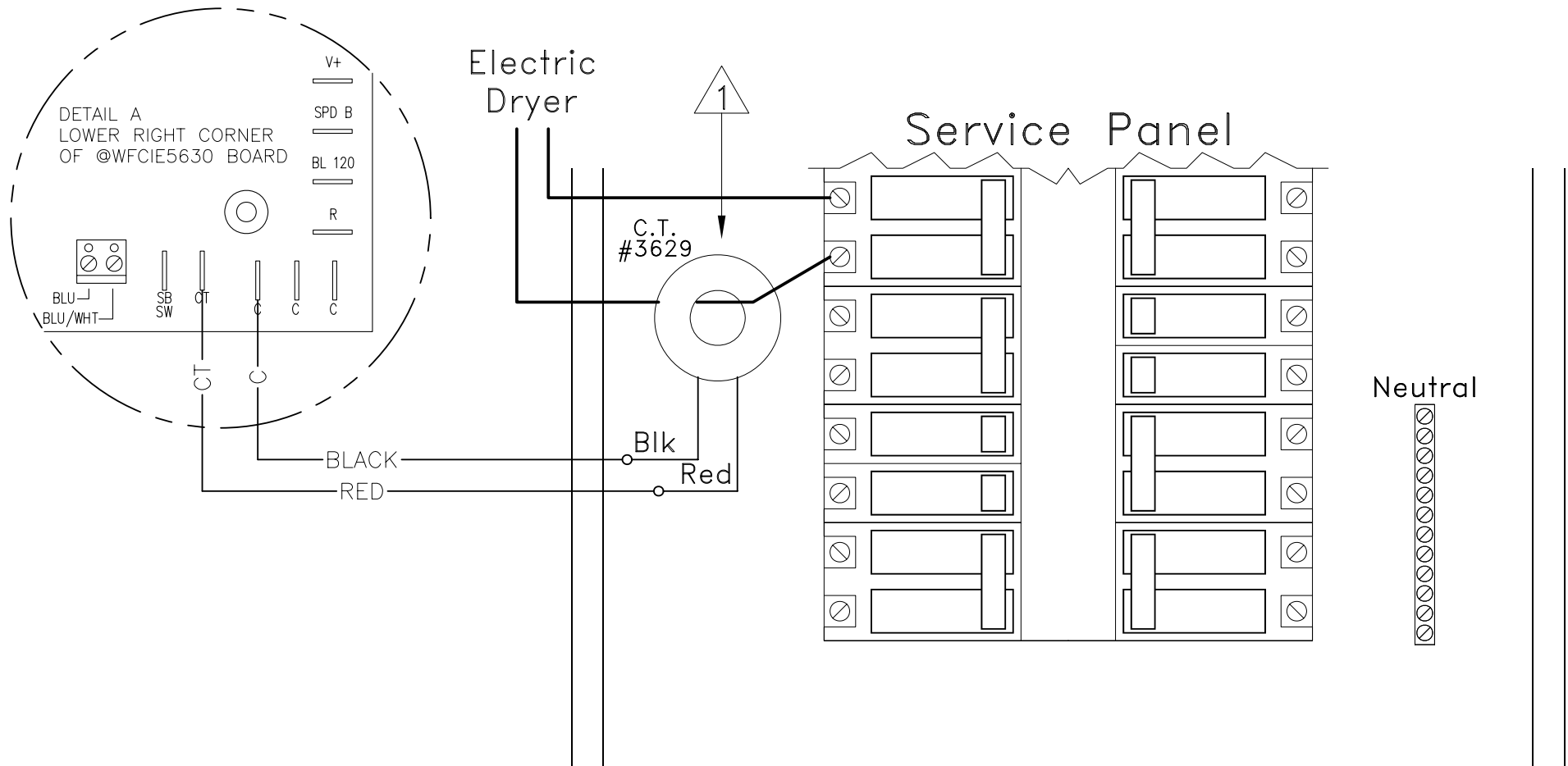

NOTES:

1. PRIMARY (MONITORED) LOADS MUST PASS THROUGH THE C.T.
2. THE MAXIMUM ALLOWED CURRENT THROUGH THE CT IS 50 AMPS.
3. THE CT TRIGGERS AT 10 AMPS.

ELECTRO-EZ-MATE VARIABLE-SPEED BLOWER OPTIONS

FURNACE – G & Y ONLY.

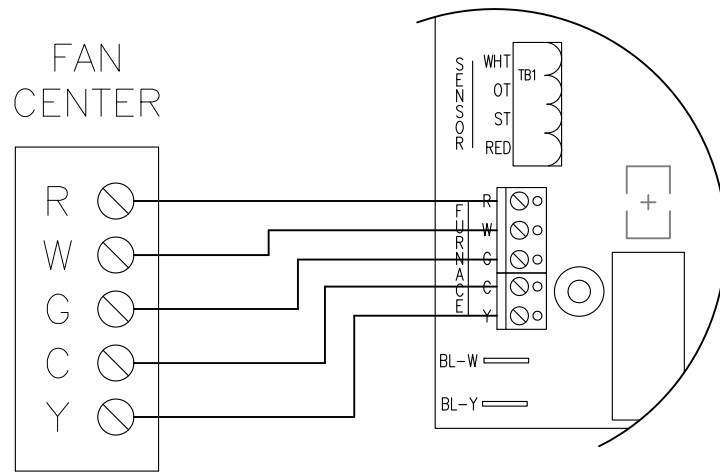

FURNACE – G, Y1, Y2
Y1 FOR HEAT, Y2 FOR COOL

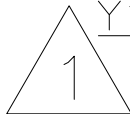

NOTES:

1. HEAT ON Y1 IS PROBABLY OK BECAUSE 10KW (34,000 BTU) ONLY REQUIRES 800CFM.

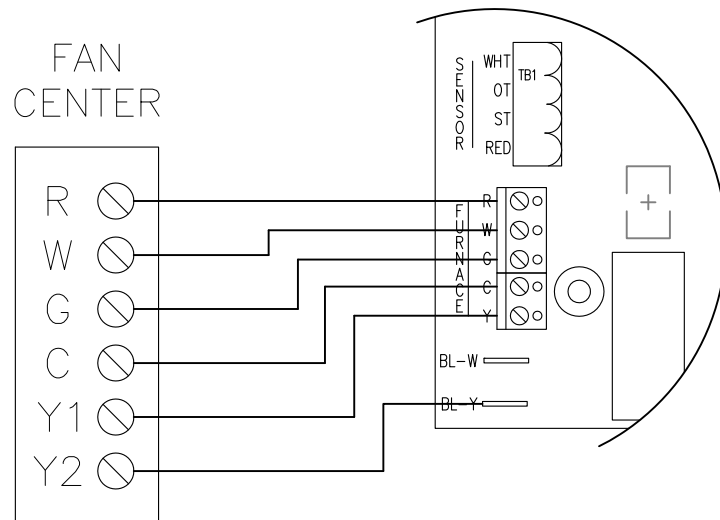

ELECTRO-EZ-MATE VARIABLE-SPEED BLOWER OPTIONS

FURNACE - G, Y1, Y2
ALWAYS RUN IN HIGH SPEED

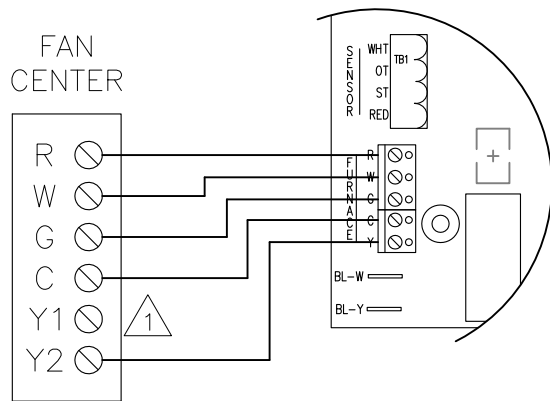

NOTES:

1. SOME FURNACES REQUIRE Y1 WITH Y2. IF THIS IS YOUR CASE, JUMPER AS REQUIRED.

1 FURNACE - G, Y1, Y2 & STAT Y2
Y1 LOW HEAT
Y2 WF ST>105 OT<30
Y1 & Y2 COOL

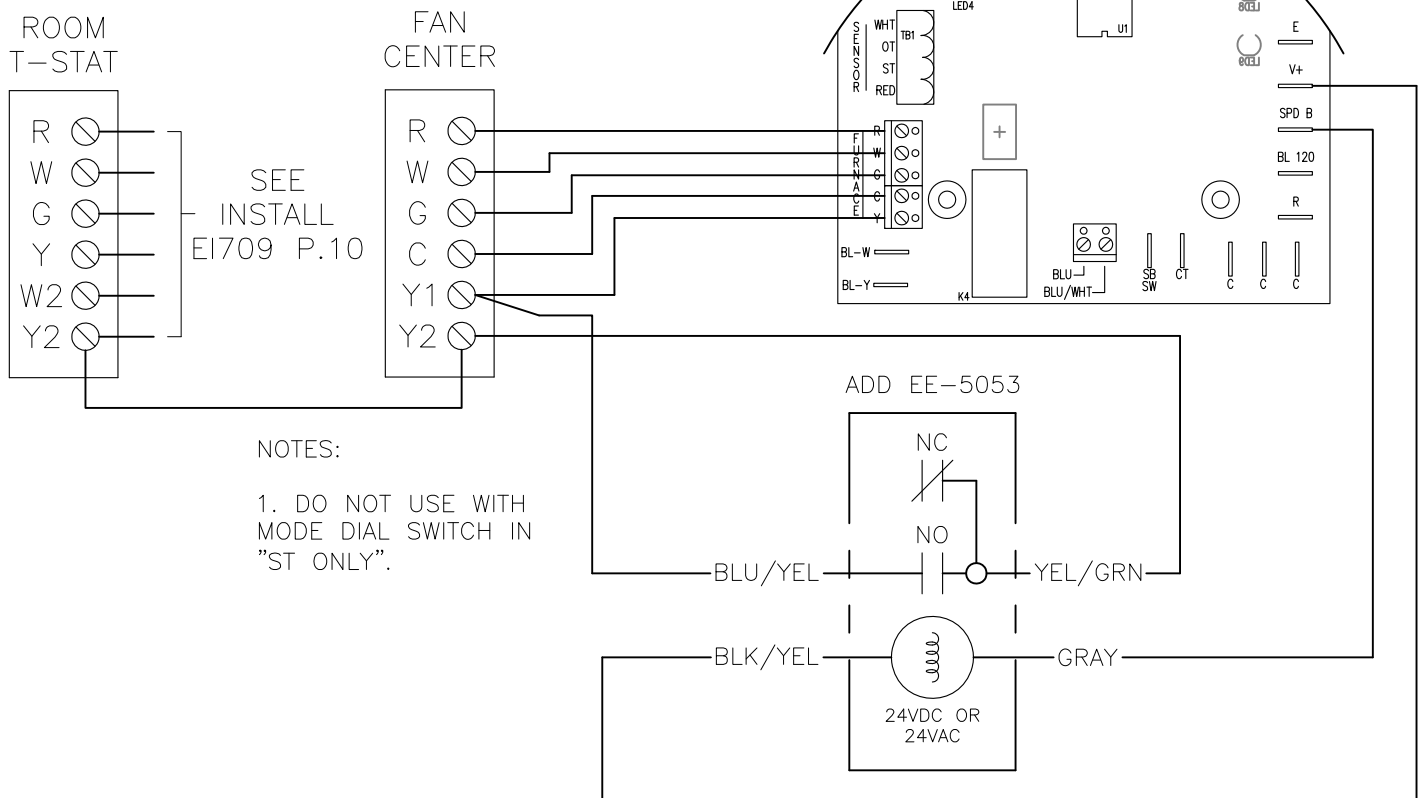

ELECTRO-EZ-MATE WIRING SCHEMATIC

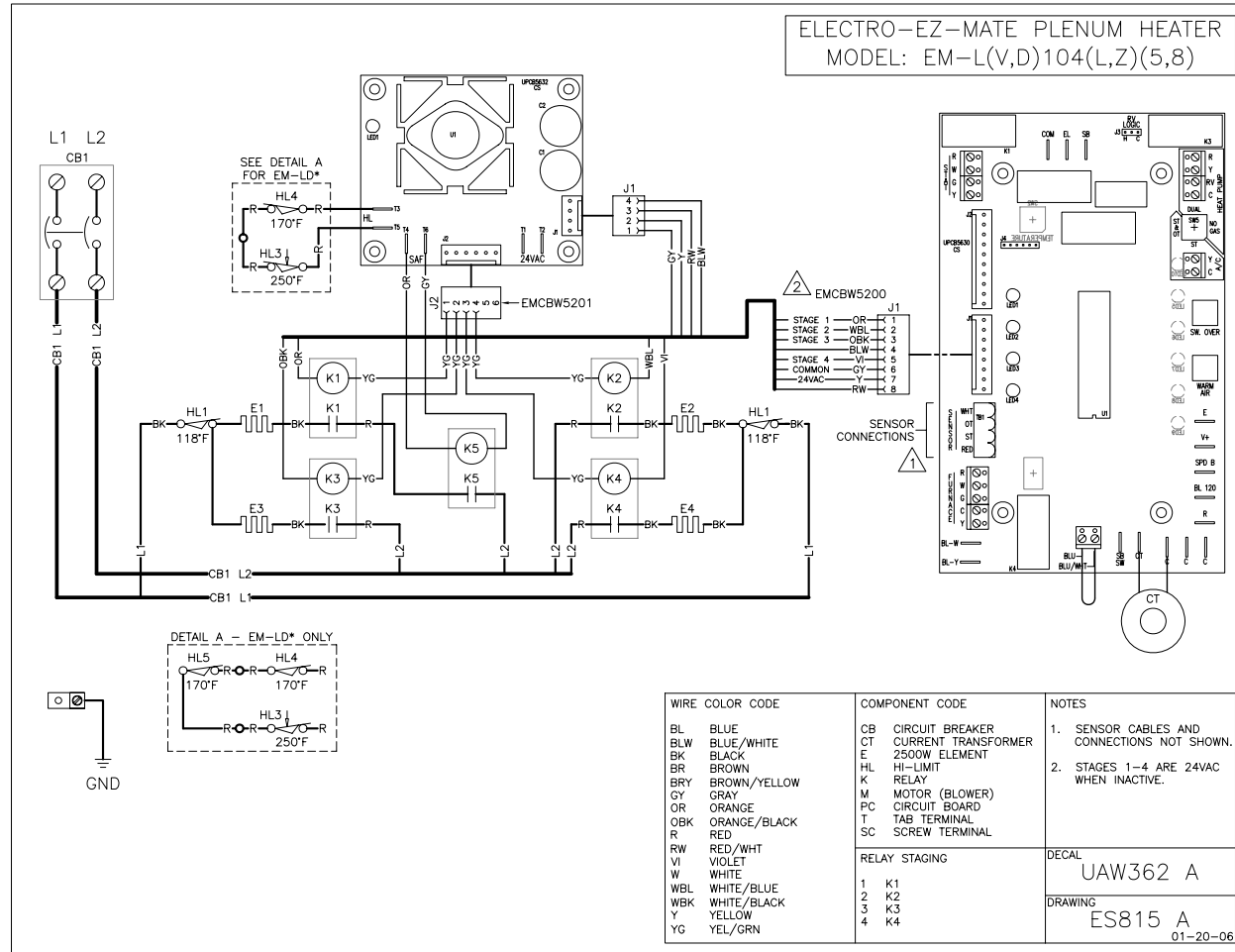

Electro Industries, Inc. Residential Limited Product Warranty

Effective November 1, 2009

Electro Industries, Inc. warrants to the original owner, at the original installation site, for a period of two (2) years from date of original purchase, that the product and product parts manufactured by Electro Industries, Inc. are free from manufacturing defects in materials and workmanship, when used under normal conditions and when such product has not been modified or changed in any manner after leaving the plant of Electro Industries, Inc. If any product or product parts manufactured by Electro Industries, Inc. are found to have manufacturing defects in materials or workmanship, such will be repaired or replaced by Electro Industries, Inc. Electro Industries, Inc., shall have the opportunity to directly, or through its authorized representative, examine and inspect the alleged defective product or product parts. Electro Industries, Inc. may request that the materials be returned to Electro Industries, Inc. at owner's expense for factory inspection. The determination as to whether product or product parts shall be repaired, or in the alternative, replaced, shall be made by Electro Industries, Inc. or its authorized representative.

Electro Industries, Inc. will cover labor costs according to the Repair / Replacement Labor Allowance Schedule for a period of ninety (90) days from the date of original purchase, to the original owner, at the original installation site. The Repair / Replacement Labor Allowance is designed to reduce the cost of repairs. This Repair / Replacement Labor Allowance may not cover the entire labor fee charged by your dealer / contractor.

TWENTY YEAR (20) LIMITED WARRANTY ON BOILER ELEMENTS AND VESSELS

Electro Industries, Inc. warrants that the boiler elements and vessels of its products are free from defects in materials and workmanship through the twentieth year following date of original purchase. If any boiler elements or vessels are found to have a manufacturing defect in materials or workmanship, Electro Industries, Inc. will replace them.

TWENTY YEAR (20) LIMITED WARRANTY ON SPIN FIN ELEMENTS

Electro Industries, Inc. warrants that the spin fin elements of its products are free from defects in materials and workmanship through the twentieth year following date of original purchase. If any spin fin elements are found to have a manufacturing defect in materials or workmanship, Electro Industries, Inc. will replace them.

FIVE YEAR (5) LIMITED WARRANTY ON OPEN WIRE ELEMENTS

Electro Industries, Inc. warrants that the open wire elements of its products are free from defects in materials and workmanship through the fifth year following date of original purchase. If any open wire elements are found to have a manufacturing defect in materials or workmanship, Electro Industries, Inc. will replace them.



CONDITIONS AND LIMITATIONS:

1. This warranty is limited to residential, single family dwelling installations only. Any commercial or multi-unit dwelling installations fall under the Electro Industries Commercial Limited Product Warranty.
2. Electro Industries, Inc. shall not be liable for performance related issues resulting from improper installation, improper sizing, improper duct or distribution system, or any other installation deficiencies.
3. If at the time of a request for service the original owner cannot provide an original sales receipt or a warranty card registration then the warranty period for the product will have deemed to begin the date the product is shipped from the factory and **NOT** the date of original purchase.
4. The product must have been sold and installed by a licensed electrician, plumbing, or heating contractor.
5. The application and installation of the product must be in compliance with Electro Industries, Inc. specifications, as stated in the installation and instruction manual, and all state, provincial and federal codes and statutes. If not, the warranty will be null and void.
6. The purchaser shall have maintained the product in accordance with the manual that accompanies the unit. Annually, a qualified and licensed contractor must inspect the product to assure it is in proper working condition.
7. All related heating components must be maintained in good operating condition.
8. All lines must be checked to confirm that all condensation drains properly from the unit.
9. Replacement of a product or product part under this limited warranty does not extend the warranty term or period.
10. Replacement product parts are warranted to be free from defects in material and workmanship for ninety (90) days from the date of installation. All exclusions, conditions, and limitations expressed in this warranty apply.
11. Before warranty claims will be honored, Electro Industries, Inc. shall have the opportunity to directly, or through its authorized representative, examine and inspect the alleged defective product or product parts. Remedies under this warranty are limited to repairing or replacing alleged defective product or product parts. The decision whether to repair or, in the alternative, replace products or product parts shall be made by Electro Industries, Inc. or its authorized representative.

THIS WARRANTY DOES NOT COVER:

1. Costs for labor for diagnosis, removal or reinstallation of an alleged defective product or product part, transportation to Electro Industries, Inc., and any other materials necessary to perform the exchange, except as stated in this warranty. Replacement material will be invoiced to the distributor in the usual manner and will be subject to adjustment upon verification of defect.
2. Any product or product part that has been damaged as a result of being improperly serviced or operated, including, but not limited to, the following: operated during construction phase, with insufficient water or air flow; allowed to freeze; subjected to flood conditions; subjected to improper voltages or power supplies; operated with air flow or water conditions and/or fuels or additives which cause unusual deposits or corrosion in or on the product; chemical or galvanic erosion; improper maintenance or subject to any other abuse or negligence.
3. Any product or product part that has been damaged as a result of natural disasters, including, but not limited to, lightning, fire, earthquake, hurricanes, tornadoes or floods.
4. Any product or product part that has been damaged as a result of shipment or handling by the freight carrier. It is the receiver's responsibility to claim and process freight damage with the carrier.
5. Any product or product part that has been defaced, abused or suffered unusual wear and tear as determined by Electro Industries, Inc. or its authorized representative.
6. Workmanship of any installer of the product or product part. This warranty does not assume any liability of any nature for unsatisfactory performance caused by improper installation.
7. Transportation charges for any replacement product, product part or component, service calls, normal maintenance; replacement of fuses, filters, refrigerant, etc.

THESE WARRANTIES DO NOT EXTEND TO ANYONE EXCEPT THE ORIGINAL PURCHASER AT RETAIL AND ONLY WHEN THE PRODUCT IS IN THE ORIGINAL INSTALLATION SITE. THE REMEDIES SET FORTH HEREIN ARE EXCLUSIVE.

ALL IMPLIED WARRANTIES, INCLUDING WARRANTIES OF MERCHANTABILITY AND FITNESS FOR A PARTICULAR PURPOSE, ARE HEREBY DISCLAIMED WITH RESPECT TO ALL PURCHASERS OR OWNERS. ELECTRO INDUSTRIES, INC. IS NOT BOUND BY PROMISES MADE BY OTHERS BEYOND THE TERMS OF THESE WARRANTIES. FAILURE TO RETURN THE WARRANTY CARD SHALL HAVE NO EFFECT ON THE DISCLAIMER OF THESE IMPLIED WARRANTIES.

ALL EXPRESS WARRANTIES SHALL BE LIMITED TO THE DURATION OF THIS EXPRESS LIMITED WARRANTIES SET FORTH HEREIN AND EXCLUDE ANY LIABILITY FOR CONSEQUENTIAL OR INCIDENTAL DAMAGES RESULTING FROM THE BREACH THEREOF. SOME STATES OR PROVINCES DO NOT ALLOW THE EXCLUSION OR LIMITATION OF INCIDENTAL OR CONSEQUENTIAL DAMAGES, SO THE ABOVE LIMITATIONS OR EXCLUSIONS MAY NOT APPLY. PRODUCTS OR PARTS OF OTHER MANUFACTURERS ATTACHED ARE SPECIFICALLY EXCLUDED FROM THE WARRANTY.

THIS WARRANTY GIVES YOU SPECIFIC LEGAL RIGHTS, AND YOU MAY HAVE OTHER RIGHTS WHICH VARY UNDER THE LAWS OF EACH STATE. IF ANY PROVISION OF THIS WARRANTY IS PROHIBITED OR INVALID UNDER APPLICABLE STATE OR PROVINCIAL LAW, THAT PROVISION SHALL BE INEFFECTIVE TO THE EXTENT OF THE PROHIBITION OR INVALIDITY WITHOUT INVALIDATING THE REMAINDER OF THE AFFECTED PROVISION OR THE OTHER PROVISIONS OF THIS WARRANTY.